

Anvil Desking.

Product Specifications



Innovative Thinking • Responsive Support • Open Communication

myolg.online

Anvil Desking.

Introducing the Anvil Workstation: the next level in office desk design. Building upon the tremendous success of the Axis range, the Anvil range takes it to new heights.

Experience the elegance of the perfectly proportioned 50mm loop endleg, designed to enhance executive offices with its sleek appeal. With a variety of quick ship configurations available, Anvil Desks ensure speedy delivery without compromising on style.

Whether you're seeking a stylish solution for a single office or a small open plan zone, Anvil Desking are the answer. They seamlessly integrate with the Axis storage range, maximizing functionality and aesthetics.

Flexibility is key with the Anvil Loop Leg bench desking, offering both side by side and back to back configurations to suit any space. The Loop legs, combined with fully adjustable central legs, guarantee exceptional stability, even on the most uneven floor surfaces.

Key Features

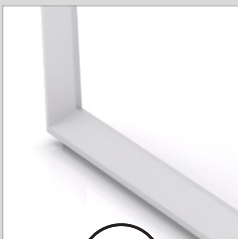

A. Superb Aesthetics

Shadowline triangular end frames legs create a unique 3D effect for a beautiful and stylish finish.

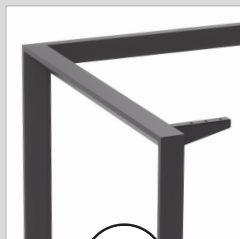

B. Strong Construction

Piece of mind with 2mm steel frame for extra strength & stability.

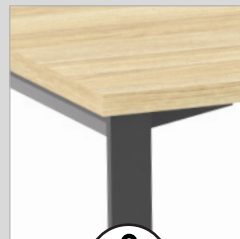

C. Reinforced Build

Extra top support brackets for even greater bracing and increased weight rating.

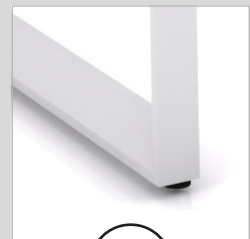

D. Adjustable Feet

30mm height adjustment in foot for those unlevel office floors.

Anvil Desking.

In Detail



Fast Assembly

Includes required tools and configured to make assembly time even faster.



Warranty

10 year warranty is the best in it's class giving you peace of mind.



Powdercoat Finish

White or Black powdercoat provides protection from corrosion, rust, UV and is easy to clean.



Customise

Multiple rail positions on the frame means less worry about the rails interfering with your power box.



Cable Management Options

A variety of cable trays and power/data options are available to suit any office needs.

Screens & Cable Management

Wide range of screens, modesties and cable trays & power/data options available.

Worktop

Available in studio white or new oak with matching 2mm PVC edge.

E0 Grade Worktop

Super low emission melamine worktops with matching hardedge to take the knocks.

Extra Top Supports

Makes for solid bracing.

Superb Aesthetics

Shadowline triangular endleg design enhances the 3D effect.

10 Year Warranty
Best in it's class

Fast Assembly
All tools included & configured for quick install

Strong Construction

2mm steel for extra strength & stability.

Powdercoat Frame

Black or White powdercoat finish provides added protection & easy cleaning.

Adjustable Feet

30mm height adjustment in foot for unlevel floors.



* Refer to page 7 for Ratings & Certifications details.

Anvil Desking.

Colour Options



Anvil Single Sided Desk
White Frame with New Oak Worktop
Black frame & White worktop also available



Anvil Double Sided Desk
with Studio50 Screen
Black Frame with White Worktop
White frame & New Oak worktop also available



Anvil Desk & Return
Black Frame with White Worktop
White frame & New Oak worktop also available



Anvil 90° Single Sided Desk
Black Frame with New Oak Worktop
White frame & White worktop also available



Anvil 120° Single Sided Desk
White Frame with White Worktop
Black frame & New Oak worktop also available

Melamine Worktop Colour Options



New Oak



White

Powdercoated Frame Colour Options



Black



White



Anvil Desking.

Optional Upgrades

AcoustiQ Screens (clamp on)

10 mm AcoustiQ pinnable substrate
100% Polyester recycled PET

Cast aluminium clamps in white/
black powdercoat (3 types available)

Square finishing on bottom
and 50 mm radius on top

Radius18 Screens

Standard height 400 mm above desk
(can be changed on request)

18 mm nominal thickness

Black Clamp Brackets

Studio50 Screens

Standard height 500 mm above desk
(can be changed on request)

50 mm thickness

Hidden Brackets



Studio50 & Radius18 Screen Colour Options

Breathe



Splice



Motion Felt (Price on Application)



AcoustiQ Screen Colour Options



Anvil Desking.

Dimension - Specifications

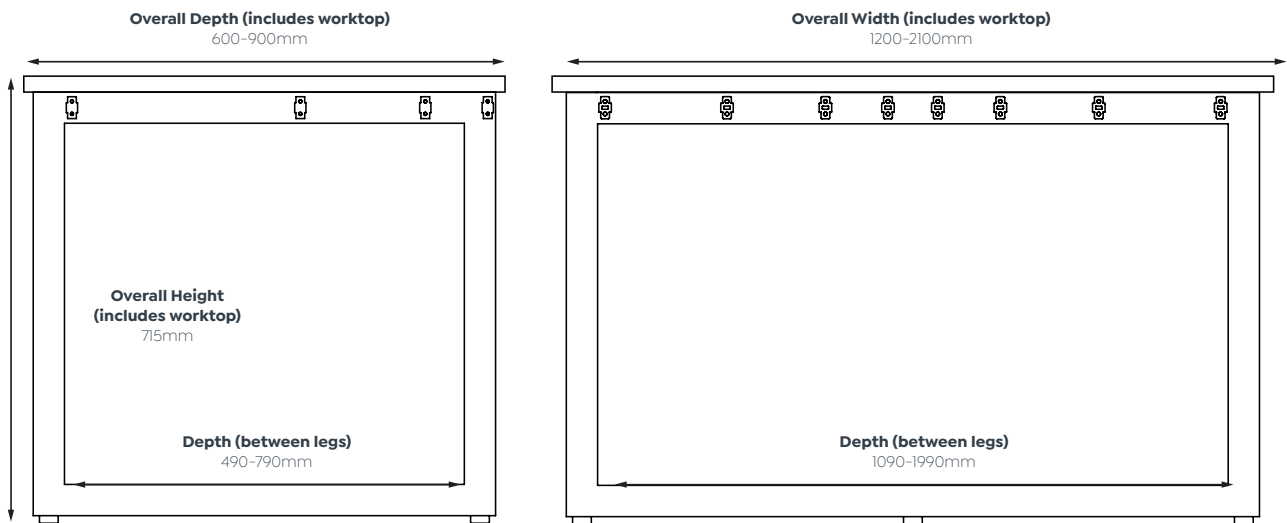

Screen Dimensions - Studio50 Hung Screen

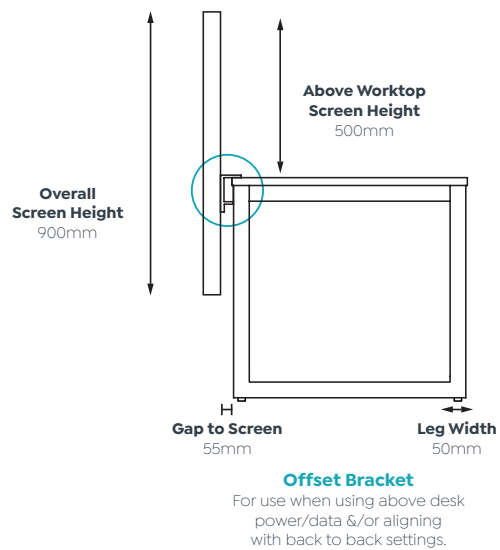
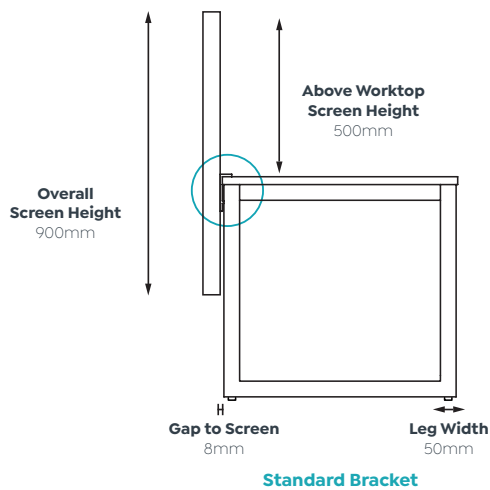

90° & 120° Dimensions

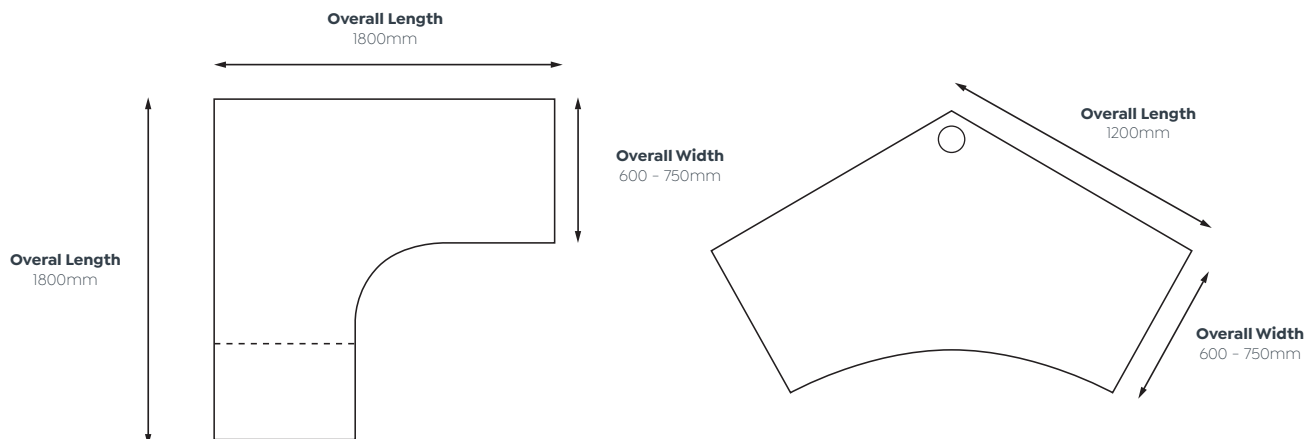

Anvil Desking.

Workstation Configurations

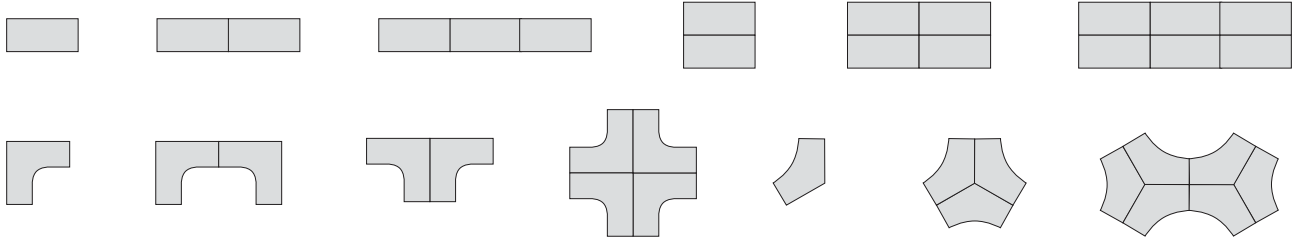

Available Sizes

Single Sided

1200 x 600mm	1600 x 600mm	1800 x 900mm
1200 x 750mm	1600 x 750mm	2100 x 900mm
1500 x 600mm	1800 x 600mm	
1500 x 750mm	1800 x 750mm	

Double Sided

2 x 1200 x 600mm	2 x 1500 x 800mm	2 x 1800 x 600mm
2 x 1200 x 750mm	2 x 1600 x 600mm	2 x 1800 x 750mm
2 x 1500 x 600mm	2 x 1600 x 750mm	2 x 1800 x 800mm
2 x 1500 x 750mm	2 x 1800 x 800mm	

Single 90°

1800 x 1800 x 600mm
1800 x 1800 x 750mm

Single 120°

1200 x 1200 x 600mm
1200 x 1200 x 750mm

Desk with Return (left or Right hand)

1800 x 600/900 x 600mm
1800 x 750/900 x 600mm
1800 x 900/900 x 600mm
1800 x 600/1200 x 600mm
1800 x 750/1200 x 600mm
1800 x 900/1200 x 600mm

White/Black Powdercoated Legs & Frame



Suits worksurface depth of

600 - 900mm

To Suit Worktop Length

900 - 1300mm

1200 - 1600mm

1500 - 1900mm

1800 - 2100mm

OLG's Ratings & Certifications.



10 Year Warranty

OLG Warranty promises the original purchaser that it will repair or replace with comparable product, at its option and free of charge (for material and components), any product, part or component which fails under normal use over the duration of the specified warranty term (taken from the date of purchase). Normal commercial usage is defined as the equivalent of a single shift, 40 hour work-week.



Weight Rating

All seating products have an OLG endorsed 120kg minimum weight rating. All OLG seating products are designed with reference to relevant international standards, including ANSI/BIFMA and AS/NZS. These standards stipulate strength & durability requirements and give the user confidence about the product's longevity. OLG's ISO certified factories use propriety test rigs to issue OLG's own weight ratings for chairs.



ISO 14001

ISO 14001 Certification is the international standard that specifies requirements for an effective Environmental Management System (EMS). It provides a framework that OLG as an organization can follow. At OLG we are using this framework as an approach to continuous improvement across all environmental aspects of our business.



ISO 9001

ISO 9001 Certification is the world's most widely recognized Quality Management System (QMS). At OLG its our guiding principle to meet the expectations and needs of our customers through quality management systems that continually monitor and manage quality across all operations to deliver consistent performance and service.



AS/NZS 4801

AS/NZS 4801 is the benchmark to assess Occupational Health & Safety Management systems for organisations. This standard contains vital information about meeting legal requirements and invaluable guidance on how to establish sustained improvement in health and safety performance in your business.



GECA Certification

GECA (The Good Environmental Choice Australia) Ecolabelling Program, operates a national third-party, independently verified ecolabel, in conformance with Environmental labels and declarations (ISO 14024), that can be applied to a wide range of products and services. This certification gives you an independent, reliable and convenient way to select OLG products and services that are certified by GECA to deliver better environmental outcomes. Anvil and Anvil (available to GECA specification by special request). EkoSystem approved as EKO Brand.



AFRDI Certification

AFRDI Certification is a set of standards covering strength, durability, stability and safety (and ergonomics in the case of desks and Desking). This means that OLG are accountable for maintaining the quality of our products, submitting them for regular auditing to ensure they meet the highest standards for commercial use. Applies to: Urban Mesh (Level 6 – Severe Commercial), Modulus Flip Table (Level 3 – Severe Commercial, tested with 1500 x 750 top and Agile+ Single Sided Dual Motor Electric Desk).



BIFMA Certification

BIFMA Certification focuses on safety and performance standards developed by the BIFMA Engineering Committee. The standards provide manufacturers, specifiers, and users with a common basis for evaluating safety, durability, and the structural adequacy of the specified furniture, independent of construction materials. The standards define specific tests, laboratory equipment to be used, the conditions of test, and the minimum acceptance levels to be used in evaluating these products. Applies to: Balance Executive, Balance Task, Optic Chair, Adapta Chair, Game Chair 4 leg, Game Chair 4 leg with seat and back pads, Game Sled, Game Sled with seat and back pads, Agile+, Agile Electric 2-Column single motor, Motion Sync



Australian Trusted Trader

Australian Trusted Trader Certification is a standard that rewards companies showing compliant behaviour, secure supply chain with strong security practices, to enjoy a wide range of trade facilitation benefits. OLG have held this status since 2017.



FSC

FSC is the leading catalyst and defining force for improved forest management and market transformation, shifting the global forest trend toward sustainable use, conservation, restoration, and respect for all. Applies to: Anvil timber legs



GREENGUARD Certification

A GREENGUARD Certification ensures that a product has met some of the world's most rigorous and comprehensive standards for low emissions of volatile organic compounds (VOCs) into indoor air. GREENGUARD Gold Certification offers certification criteria that considers safety factors to account for sensitive individuals (such as children and the elderly), and ensures that a product is acceptable for use in environments such as schools and healthcare facilities.

Anvil Desking.

Cheat Sheet Quick Guide

Standard Features

Extra fast assembly time

50 x 50 mm triangle endlegs, 50 x 25 mm rails

30 mm height adjustment in each foot

Arctic white or black powdercoat finish

Multiple rail positions on each frame

Worktop height 715 mm (incl worksurface)

Melamine Worktop - 25 mm E0 grade substrate finished in studio white or new oak with matching 2 mm PVC edge

GECA Certification

10 year warranty

E0 grade worktop

2 mm thick steel construction frame for extra strength & stability

Melamine Worktop Colour Options



Powdercoated Frame Colour Options



Studio50
Screens are
Australian
Made.

Breathe

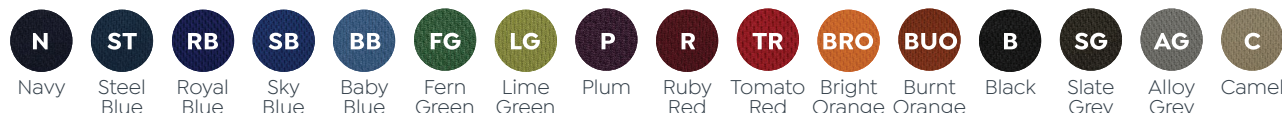

Splice



Motion Felt (Price on Application)



AcustiQ Screen Colour Options



Additional Options.

Storage



Axis Mobile Drawers
Two Box Drawers + One File Drawer - Gang Locking



Axis Mobile Drawers
Four Box Drawers Gang Locking



Axis Caddy Mobile Bookcase
2 x Adjustable Shelves



Axis Caddy Mobile Bookcase
1 x Drawer Insert
Left or Right Handed Configuration



Axis Caddy Mobile
2 x Drawer Insert



Axis Caddy Mobile Bookcase
1 x Tambour Insert
Left or Right Handed Configuration



Axis Caddy Mobile Bookcase
1 x Tambour Insert
1 x Drawer Insert
Left or Right Handed Configuration



Axis Caddy Mobile
2 x Tambour Insert



Agile Steel Caddy L/H
Metal caddy unit with tambour and 3 drawers. Available in 2 Powdercoats



Agile Steel Caddy R/H
Metal caddy unit with tambour and 3 drawers. Available in 2 Powdercoats



Agile Regular Steel Mobile
Metal mobile drawer unit with 2 drawers and 1 file. Available in 2 Powdercoats



Agile Narrow Steel Mobile
Metal mobile drawer unit with 2 drawers and 1 file. Available in 2 Powdercoats



Axis Credenza 1200 Two Levels
2 x 25 mm adjustable shelves



Axis Credenza 1800 Two Levels
1 x 18 mm adjustable shelves
4x hinged locking doors



Axis Bookshelf Three Levels
2 x 25 mm adjustable shelves



Axis Bookshelf Five Levels
3 x 25 mm adjustable shelves
1 x fixed shelf



Axis Cupboard Locking Three Levels
2 x 18mm adjustable shelves



Axis Cupboard Locking Five Levels
3 x 18 mm adjustable shelves
1 x fixed shelf



Axis Tower Bookcase
2 x Adjustable Shelves



Axis Tower Bookcase
1 x Drawer Insert

Accessories



Monitor Arms
Axis / Studio50 Brackets



Cable Management
Above Desk / Below Desk



Modesties
Melamine / Metal



Laptop Riser
Available in Black



Deskmount Shelves
Studio White
243 high x 600 wide x 300 deep



Anvil double sided desks with Studio50 screens and Urban Mesh Chairs



We'd love to help.

02 8188 2732

info@olgoffice.com

myolg.online

olgoffice.com

officedesigner.net

motionoffice.com

officefitoutcalculator.com.au

myolgpricelist.online

acoustiq.com.au

Innovative Thinking • Responsive Support • Open Communication